



VARTA SILVER dynamic AGM

Vehicle Key Benefits



xEV ready – ensuring safety and reliability for all current and future vehicle demands



Best start-stop performance for maximum fuel economy – as the start-stop-system can be operated as often as possible



90% of a newly produced VARTA AGM battery consists of recycled lead



Original Spare Parts ensure the replacement battery has the same quality as the original one



Patented PowerFrame® grid for reliable starting power, fast recharge and corrosion resistance.

For more information visit varta-automotive.com

ORDER INFORMATION DATA SHEET FOR WWW.AUTOALL.AZ

European Type No. (ETN):	580901080
Article Number:	580901080J382
Short Code:	A6
Barcode:	4016987165522
UK Code:	115AGM
Packaging Unit:	1
Quantity per Pallet:	36

AUTOALL.AZ

TECHNICAL INFORMATION DATA SHEET FOR WWW.AUTOALL.AZ

Voltage [V]:	12	Base Hold-down:	B13
Battery Capacity [Ah]:	80	Layout:	0
CCA, EN [A]:	800	Terminal Types:	1
Length [mm]:	315	Case Size:	H7/LN4
Width [mm]:	175	Weight filled (kg):	22,76
Height [mm]:	190		

AUTOALL.AZ

DRAWINGS

B13

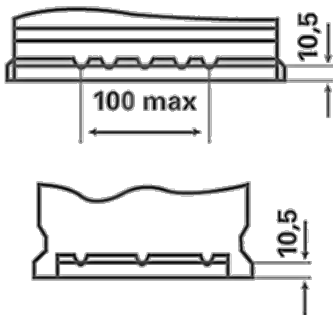

0

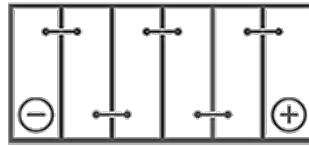

1

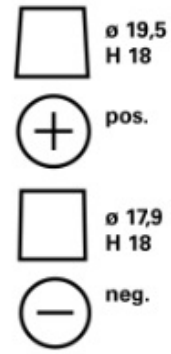

3

